

DIESEL ENGINE

MODEL 3DSP-23

Performances

Ratings		3000 rpm	
		PRIME	STAND-BY
Rated Output	kWm	21	23

Note:

PRIME POWER: The prime power is the maximum power available with varying loads for an unlimited number of hours. The average power output during a 24h period of operation must not exceed 80% of the declared prime power between the prescribed maintenance intervals and at standard environmental conditions. A 10% overload is permissible for 1 hour every 12 hours of operation.

STAND-BY POWER: The stand-by power is the maximum power available for a period of 500 hours/year with a mean load factor of 90% of the declared stand-by power. No kind of overloads is permissible for this use.

Specifications

Mechanical system

Engine model	3DSP-23
Engine type	In-line, 4 stroke, water cooled
Combustion type	Direct Injection
Cylinder type	Wet liner
Air intake type	Normally Aspirated
Cylinder No.	3
Bore*Stroke(mm)	80*90
Total displacement(L)	1.357
Compression ratio	18:1
Firing order	1-3-2
Injection timing	15°±1°
Speed governor	Mechanical ≤8%
Exhaust temperature (°C)	≤600
Mean Effective Pressure (KPa)	627
Noise Level(dBA)	≤93
Exhaust gas back pressure(KPa)	3.3
Exhaust flow (m ³ /h)	385
Cooling air flow (m ³ /h)	210
Air for combustion flow (m ³ /h)	160
Piston Speed(m/s)	9
Dry weight (kg)	165
Dimension(L*W*H)(mm)	567*494*610 (without radiator)
Rotation	Counter clockwise viewed from flywheel
Flywheel housing/flywheel	SAE4/ 7.5"

Mechanism

Type	Over head valve
Valves per cylinder	2
Valve lash(cold state)	Air intake valve 0.20-0.30mm Exhaust valve 0.25-0.35mm

Valve timing (crankshaft rotating angel)

Air intake valve open	14.5° before top dead center
Air intake valve close	37.5° after bottom dead center
Exhaust valve open	56° before bottom dead center
Exhaust valve close	12° after top dead center

Specific fuel consumption

rpm	3000
Fuel consumption (g/kWh)	≤265

Oil consumption

Oil consumption(g/kWh)	≤0.795
------------------------	--------

Fuel system

Fuel injector pump	BQ pump
Governor model	RSV full range type
Feed pump	Mechanical type
Injection nozzle	multi holes type
Fuel filter	Spin-on type
Fuel	Diesel

Lubrication system

Type	Mixed type, pressure and splash lubrication
Oil pump Displacement/speed (L/min/r/min)	Inner and outer rotor type 21/1500
Oil filter	Spin-on type
Lube oil total system capacity	7.5L including pipes, filters etc.

Cooling system

Cooling method	Water cooled, forced circulation
Coolant capacity: engine only	4L
Engine + radiator	9L
Water pump type	Centrifugal type driven by belt
Water pump capacity(L/min)	≥80
Thermostat	Opening temp.73°C
Cooling fan	Φ 380mm, 7blades, PA
Belt	Twin for safety

Electronic system

Charging alternator	14v/350w
AVR	Built-in type
Starting motor	12v/3.8kW
Battery capacity	12v/100Ah

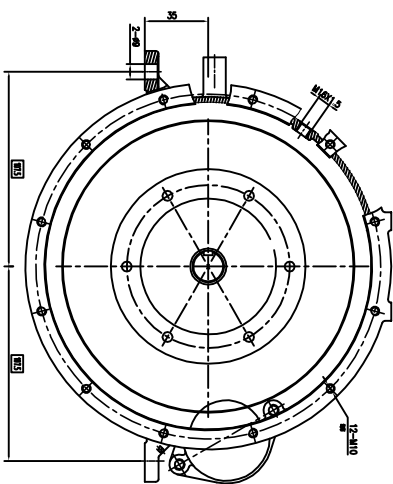
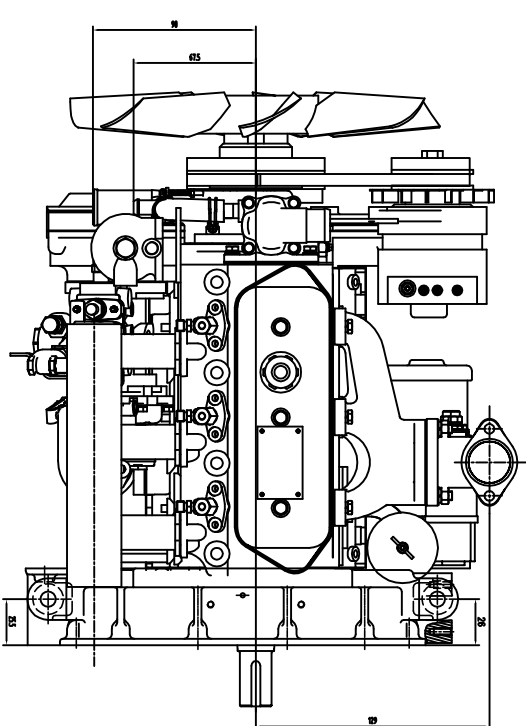
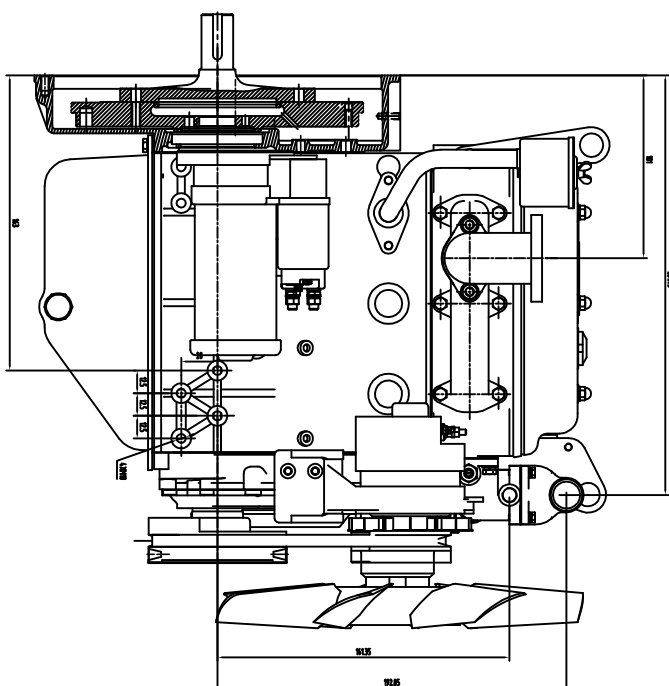
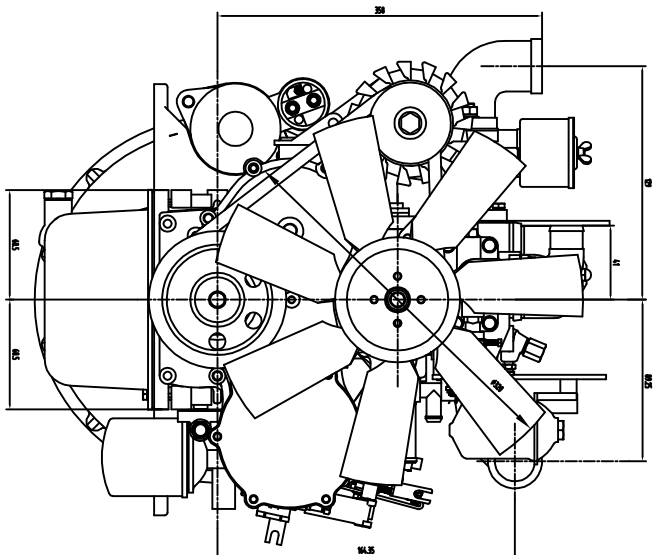
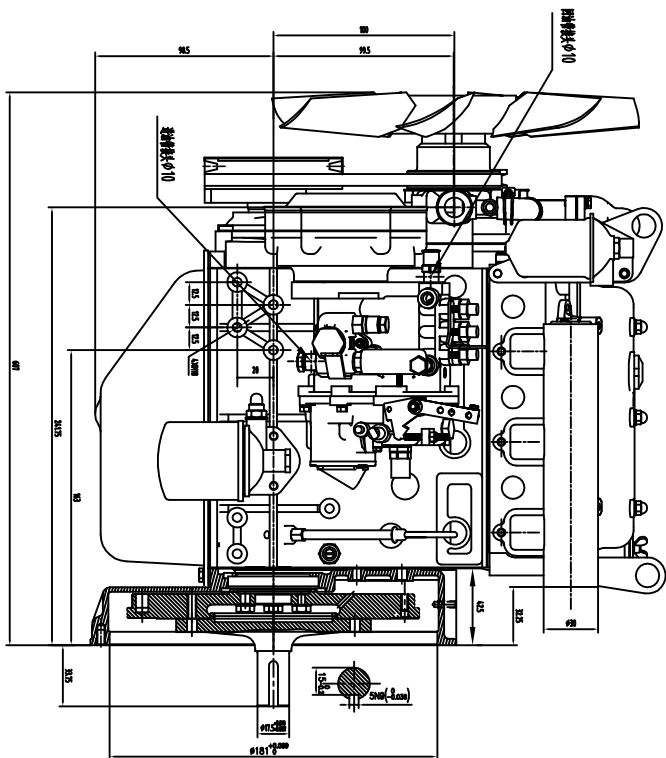

進料管中心

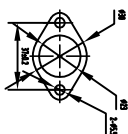

TITLE		CUSTOMER	
DESSIN ENGINE ASSEMBLY		-	
SCALE	1/5	DATE	19/09/20
DRAWN BY		CHECKED BY	
APPROVED BY		CONTRACT NO.	30SP-23
CLIENT APPROVAL		JOB NO.	3010000-00
REVISION			