

DIESEL ENGINE

MODEL 6DSG-182

Performances

Ratings		1500 rpm		1800 rpm	
		PRIME	STAND-BY	PRIME	STAND-BY
Rated Output	kWm	165	182	175	192.5

Note:

PRIME POWER: The prime power is the maximum power available with varying loads for an unlimited number of hours. The average power output during a 24h period of operation must not exceed 80% of the declared prime power between the prescribed maintenance intervals and at standard environmental conditions. A 10% overload is permissible for 1 hour every 12 hours of operation.

STAND-BY POWER: The stand-by power is the maximum power available for a period of 500 hours/year with a mean load factor of 90% of the declared stand-by power. No kind of overloads is permissible for this use.

Specifications

Mechanical system

Engine model	6DSG-182 (50hz)	6DSG-182 (60Hz)
Engine type	In-line, 4 stroke, water cooled	
Combustion type	direct injection	
Cylinder type	Wet liner	
Air intake type	Turbocharger and intercooler	
Cylinder No.	6	
Bore*Stroke(mm)	113*135	
Total displacement(L)	8.12	
Compression ratio	16:1	
Firing order	1-5-3-6-2-4	
Injection timing	17°±1°	
Speed governor	Mechanical ≤5%, (If choose Electronic governor, ≤1%)	
Exhaust temperature (°C)	≤600	
Mean Effective Pressure (KPa)	1626	
Noise Level(dBA)	≤95	
Exhaust gas back pressure(KPa)	6.5	
Exhaust flow (m ³ /h)	625	
Cooling air flow (m ³ /h)	14960	
Air for combustion flow (m ³ /h)	623	
Piston Speed(m/s)	6.75	8.1
Dry weight (kg)	650	
Dimension(L*W*H)(mm)	1267*796*1301(without radiator)	
Rotation	Counter clockwise viewed from flywheel	
Flywheel housing/flywheel	SAE3/ 11.5"	

Mechanism

Type	Over head valve
Valves per cylinder	2
Valve lash(cold state)	Air intake valve 0.30-0.40mm Exhaust valve 0.40-0.50mm

Valve timing (crankshaft rotating angel)

Air intake valve open	12° before top dead center
Air intake valve close	38° after bottom dead center
Exhaust valve open	55° before bottom dead center
Exhaust valve close	12° after top dead center

Specific fuel consumption

rpm	1500	1800
100% load l/h (g/kWh)	46.21(224)	51.19(225)
80% load l/h (g/kWh)	36.97(224)	40.95(215)

Oil consumption

Oil consumption(g/kWh)	≤1.63
------------------------	-------

Fuel system

Fuel injector pump	A in-line plunger type
Governor model	RSV full range type
Feed pump	Mechanical type
Injection nozzle	P type, multi hole type
Fuel filter	Spin-on type/water separator
Fuel	Diesel

Lubrication system

Type	Fully forced pressure feed type
Oil pump Displacement/speed (L/min/r/min)	Single grade gear type 90/2800
Oil filter	Spin-on type
Lube oil total system capacity	19L including pipes, filters etc.

Cooling system

Cooling method	Water cooled, forced circulation
Coolant capacity: engine only	12L
engine+radiator	25L
Water pump type	Centrifugal type driven by belt
Water pump capacity(L/min)	≥200
Thermostat	Opening temp.60°C
Cooling fan	Φ540m, 7blades, iron

Electronic system

Charging alternator	28v/1000w
AVR	Built-in type
Starting motor	24v/5.5kW
Battery capacity	24v/180Ah

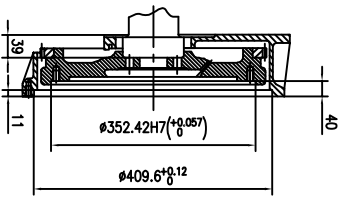
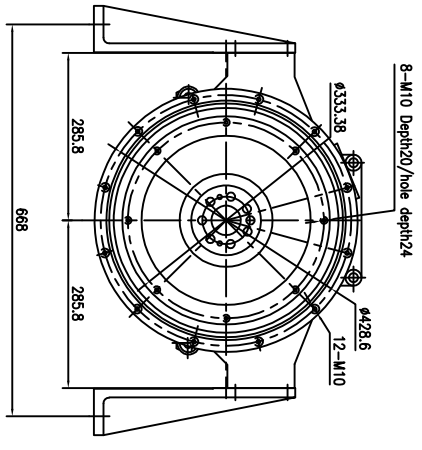
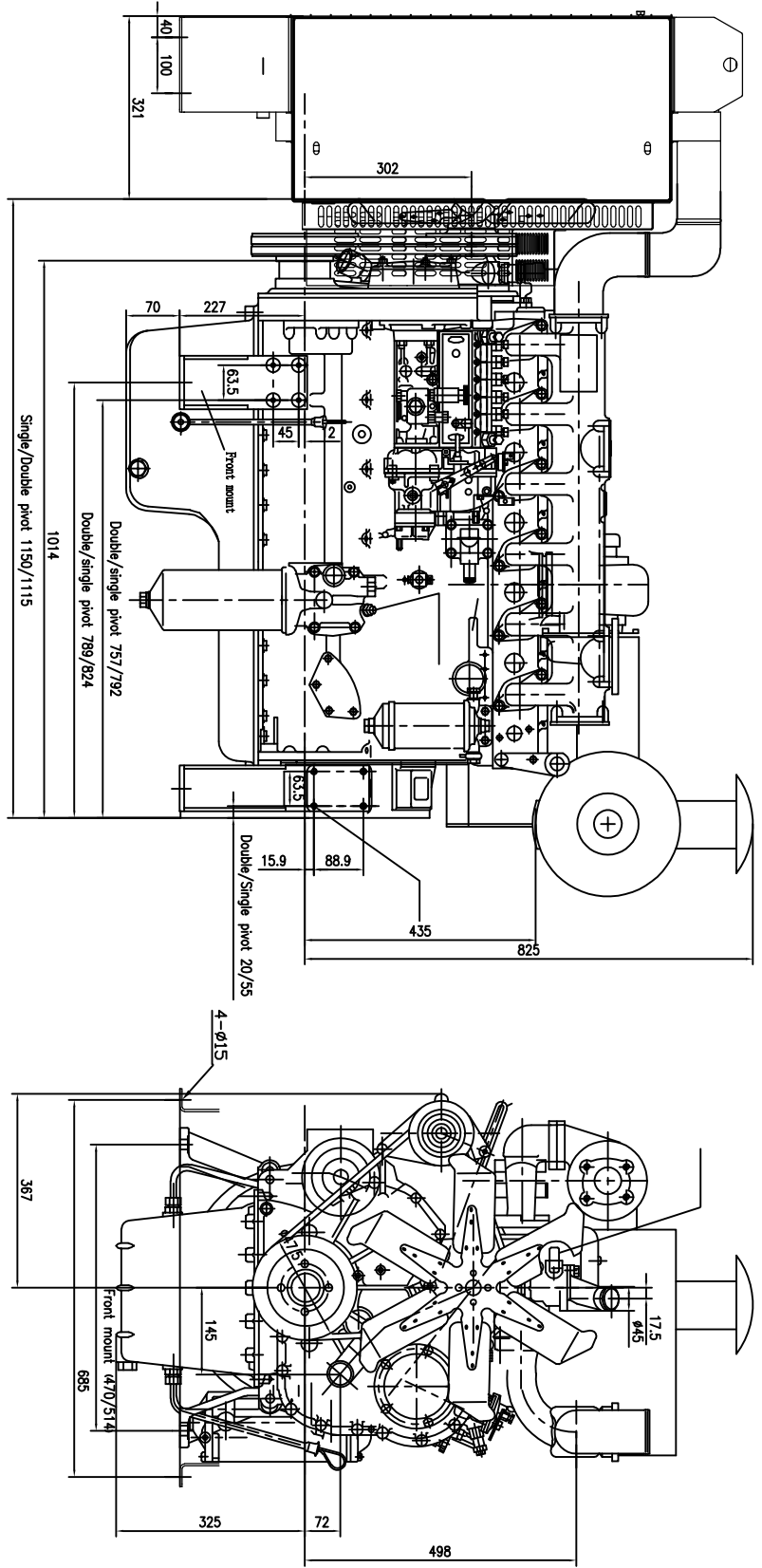

SCALE		1/5	DATE	
DRAWN BY			18/09/20	
CHECKED BY				
APPROVAL				
CLIENT APPROVAL				
CUSTOMER				
TITLE				
DESSIN ENGINE ASSEMBLY				
60SC-182				
CONTRACT NO.		Dessin No.		
JOB NO.		60SC-182		
REVISION				