

DIESEL ENGINE

MODEL 6DSG-460

Performances

Ratings		1500 rpm		1800 rpm	
		PRIME	STAND-BY	PRIME	STAND-BY
Rated Output	kWm	418	460	418	460

Note:

PRIME POWER: The prime power is the maximum power available with varying loads for an unlimited number of hours. The average power output during a 24h period of operation must not exceed 80% of the declared prime power between the prescribed maintenance intervals and at standard environmental conditions. A 10% overload is permissible for 1 hour every 12 hours of operation.

STAND-BY POWER: The stand-by power is the maximum power available for a period of 500 hours/year with a mean load factor of 90% of the declared stand-by power. No kind of overloads is permissible for this use.

Specifications

Mechanical system

	6DSG-460 (50Hz)	6DSG-460 (60Hz)
Engine model	6DSG-460 (50Hz)	6DSG-460 (60Hz)
Engine type	In-line, 4 stroke, water cooled	
Combustion type	direct injection	
Cylinder type	Dry liner	
Air intake type	Turbocharger and intercooler	
Cylinder No.	6	
Bore*Stroke(mm)	127*165	
Total displacement(L)	12.54	
Compression ratio	16:1	
Firing order	1-5-3-6-2-4	
Injection timing	14°±1°	16°±1°
Speed governor	Electronic governor, ≤1%	
Exhaust temperature (°C)	≤600	
Mean Effective Pressure (KPa)	2898	2415
Noise Level(dBA)	≤105	
Exhaust gas back pressure(KPa)	5	
Exhaust flow (kg/h)	2280	2342
Cooling air flow (m³/h)	8.5	8.5
Air for combustion flow (m³/h)	1770	1826
Piston Speed(m/s)	8.25	9.9
Dry weight (kg)	1100	
Dimension(L*W*H)(mm)	2230*780*1539(with radiator)	
Rotation	Counter clockwise viewed from flywheel	
Flywheel housing/flywheel	SAE1/ 14"	

Mechanism

Type	Over head valve
Valves per cylinder	4
Valve lash(cold state)	Air intake valve 0.30mm Exhaust valve 0.40mm

Valve timing (crankshaft rotating angel)

Air intake valve open	34°-39° before top dead center
Air intake valve close	61°-67° after bottom dead center
Exhaust valve open	76°-81° before bottom dead center
Exhaust valve close	26°-34° after top dead center

Specific fuel consumption

rpm	1500	1800
Fuel consumption (g/kWh)	≤192	

Oil consumption

Oil consumption(g/kWh)	≤0.792
------------------------	--------

Fuel system

Fuel injector pump	In-line "PW" type
Governor model	RSV full range type
Feed pump	Mechanical type
Injection nozzle	BOSCH brand, multi hole type
Fuel filter	Double and spin-on type/water separator
Fuel	Diesel

Lubrication system

Type	Fully forced pressure feed type
Oil filter	Spin-on type
Lube oil total system capacity	32L including pipes, filters etc.

Cooling system

Cooling method	Water cooled, forced circulation
Coolant capacity: engine only	20L
engine+radiator	55L
Water pump type	Centrifugal type driven by belt
Thermostat	Opening temp.71±2℃ full open temp.82℃
Cooling fan	Φ 865m

Electronic system

Charging alternator	28v/1000w
AVR	Built-in type brushless
Starting motor	24v/8.1kW brushless
Battery capacity	2pcs 12v/185Ah

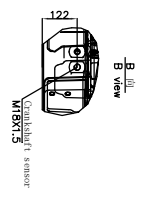
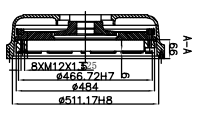
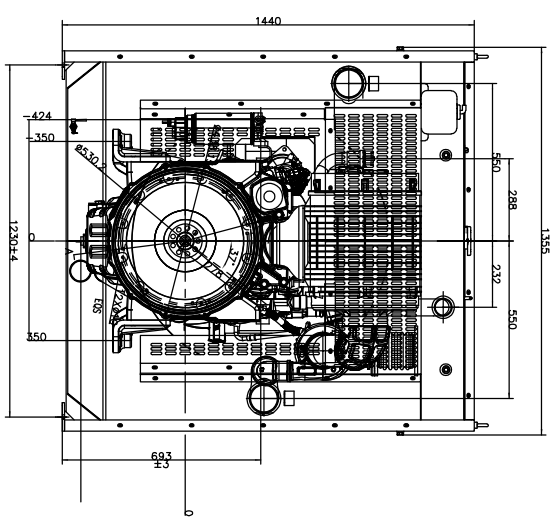
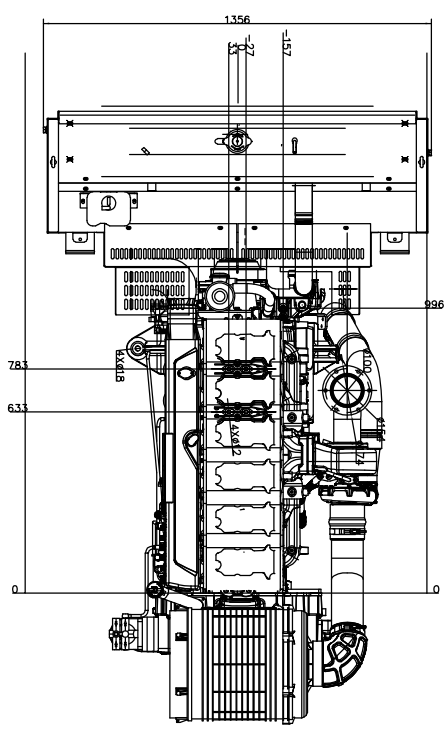
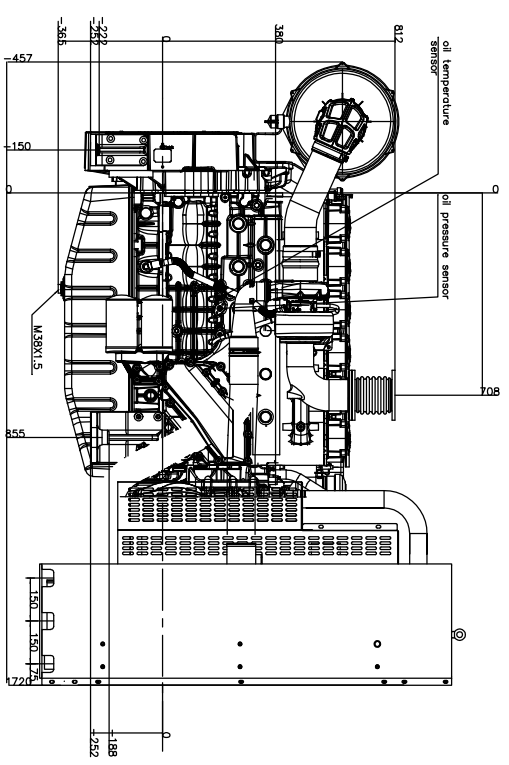
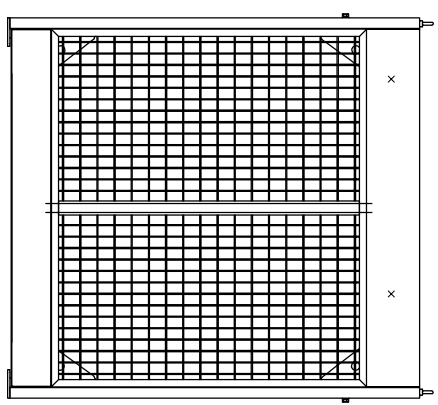
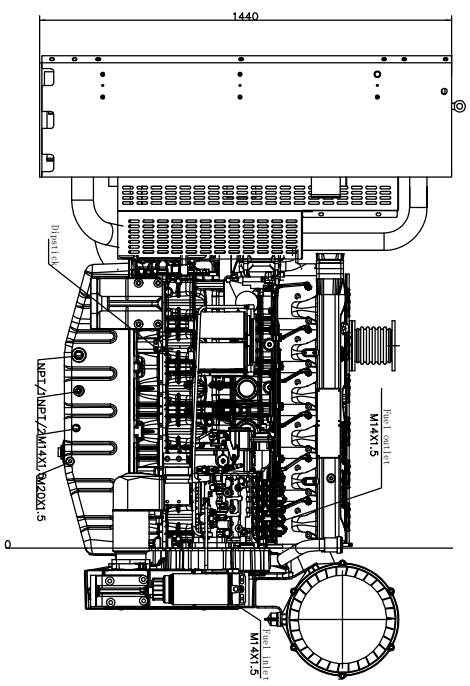

CUSTOMER		-	
TITLE		DESSIN ENGINE ASSEMBLY	
SCALE		1/5	
DATE		18/09/20	
DRAWN BY		-	
CHECKED BY		-	
APPROVAL		-	
CLIENT		-	
CONTRACT NO.		60SC-460	
JOB NUMBER		201809-03	
REVISION		-	