

DIESEL ENGINE

MODEL 6DSP-165

Performances

Ratings		2900 rpm	
		PRIME	STAND-BY
Rated Output	kWm	150	165

Note:

PRIME POWER: The prime power is the maximum power available with varying loads for an unlimited number of hours. The average power output during a 24h period of operation must not exceed 80% of the declared prime power between the prescribed maintenance intervals and at standard environmental conditions. A 10% overload is permissible for 1 hour every 12 hours of operation.

STAND-BY POWER: The stand-by power is the maximum power available for a period of 500 hours/year with a mean load factor of 90% of the declared stand-by power. No kind of overloads is permissible for this use.

Specifications

Mechanical system

Engine model	6DSP-165
Engine type	In-line, 4 stroke, water cooled
Combustion type	Direct Injection
Cylinder type	Dry liner
Air intake type	Turbocharger and intercooler
Cylinder No.	6
Bore*Stroke(mm)	105*125
Total displacement(L)	6.490
Compression ratio	17.5:1
Firing order	1-5-3-6-2-4
Injection timing	17°±1°
Speed governor	Mechanical ≤8%
Exhaust temperature (°C)	≤600
Mean Effective Pressure (KPa)	957
Noise Level(dBA)	≤99
Exhaust gas back pressure(KPa)	10
Exhaust flow (m ³ /h)	2289
Cooling air flow (m ³ /h)	1414
Air for combustion flow (m ³ /h)	990
Piston Speed(m/s)	10.4
Dry weight (kg)	710
Dimension(L*W*H)(mm)	1639*800*1140 (with radiator and air filter)
Rotation	Counter clockwise viewed from flywheel
Flywheel housing/flywheel	SAE 3/ 11.5"

Mechanism

Type	Over head valve
Valves per cylinder	2
Valve lash(cold state)	Air intake valve 0.30-0.40mm Exhaust valve 0.30-0.40mm

Valve timing (crankshaft rotating angel)

Air intake valve open	24.5° before top dead center
Air intake valve close	55.5° after bottom dead center
Exhaust valve open	54° before bottom dead center
Exhaust valve close	26° after top dead center

Specific fuel consumption

rpm	2900
Fuel consumption (g/kWh)	≤205

Oil consumption

Oil consumption(g/kWh)	≤1.52
------------------------	-------

Fuel system

Fuel injector pump	BQ pump
Governor model	RSV full range type
Feed pump	Mechanical type
Injection nozzle	multi holes type
Fuel filter	Spin-on type
Fuel	Diesel

Lubrication system

Type	Mixed type, pressure and splash lubrication
Oil pump Displacement/speed (L/min/r/min)	Inner and outer rotor type 80/2000
Oil filter	Spin-on type
Lube oil total system capacity	17L including pipes, filters etc.

Cooling system

Cooling method	Water cooled, forced circulation
Coolant capacity: engine only	10L
Engine + radiator	35L
Water pump type	Centrifugal type driven by belt
Water pump capacity(L/min)	≥180
Thermostat	Opening temp.73℃
Cooling fan	Φ490mm, 7blades, PA

Electronic system

Charging alternator	28v/1000w
AVR	Built-in type
Starting motor	24v/6.6kW
Battery capacity	24v/120Ah

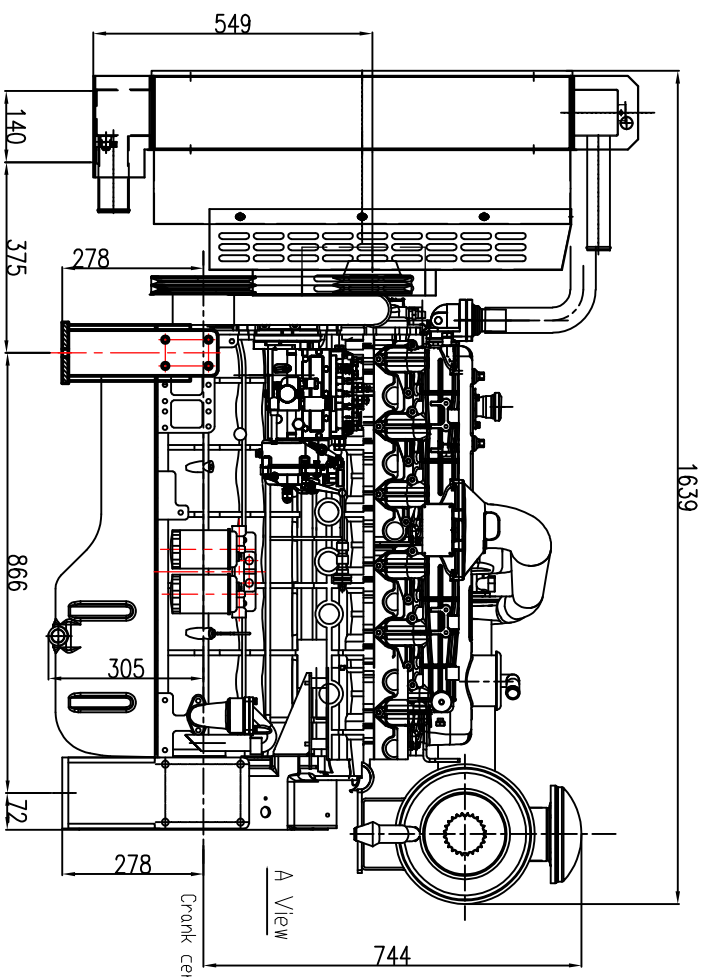

A View
Crank Center

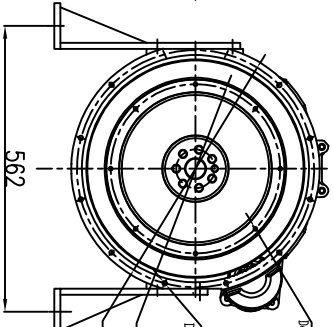
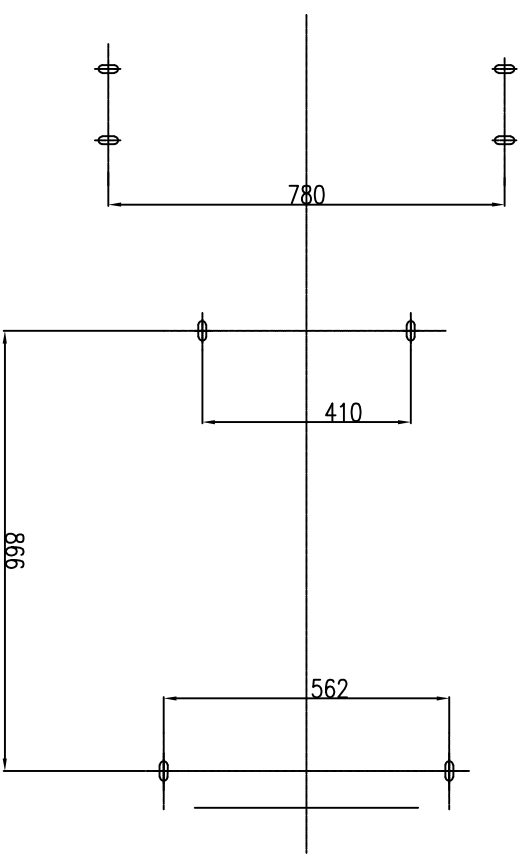

8-M10-6H
Jeep cast equally divided
12-M10-6H
Jeep cast equally divided
8-333.38
466.72

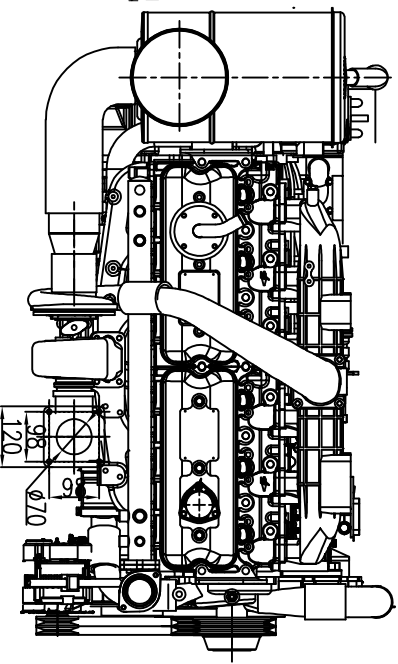
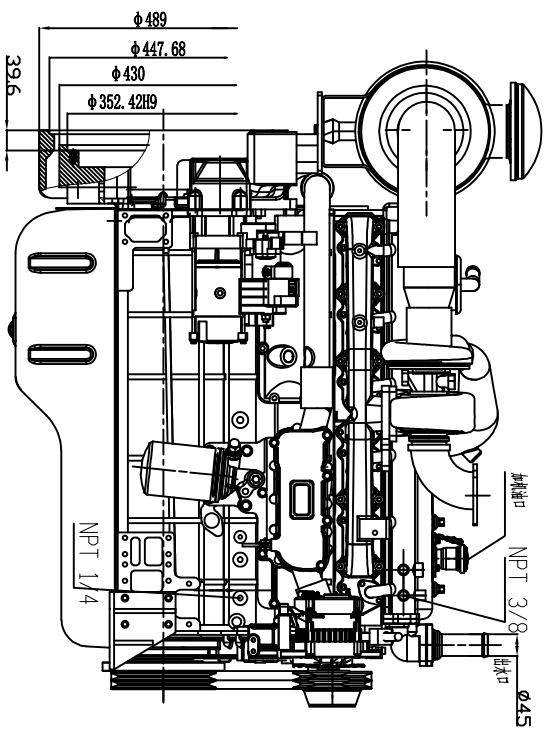

SCALE	1/5	DATE	19/09/20
DESIGNED BY		CONTRACT NO.	60SP-165
CHECKED BY		SPEC. NO.	
APPROVAL		JOB NO.	201909-03
CLIENT APPROVAL		REVISED	

DESIGN ENGINE ASSEMBLY
60SP-165

