

DIESEL ENGINE

KDP SERIES FOR FIRE PUMP

Model: 6KDP-215

Prime power 215.0KW(292HP)/3000 rpm
Standby Power 237.0KW(322HP)/3000 rpm

Engine Specifications

In-Line, 4 stroke, water-cooled, **Turbocharger and Intercooler**

Combustion type	Direct injection
Cylinders - Bore × stroke	6 - 126 × 125 mm
Displacement	9352 cc
Firing order	1 – 5–3 –6–2– 4
Compression ratio	17 : 1
Dry weight	Approx. 1150 kg
Dimension(LxWxH)	2050 × 1090 × 1290 mm
Rotation	Anti-clockwise
Flywheel / Housing	SAE # 14 / # 1

Cooling System

Cooling method	Fresh water forced type
Water pump	Centrifugal, Belt driven
Max. water Temp	95 degree C.
Cooling Fan	Blade 9EA - Ø 750 mm

Intake & Exhaust System

Max air restriction	Clean 2 kPa / Dirty 5 kPa
Exhaust back	Max 6 kPa

Electric System

Charging generator	27.5 V × 40 A
Starting motor	24 V × 8.1 kW
Battery	12 V x 2 x 150 Ah

Fuel System

Injection pump	Direct Injection type
Governor	Mechanicaltype
Feed pump	Mechanicaltype
Injection nozzle	Multi-hole type/ 0.255 mm
Opening pressure	20+0.5MPa
Fuel filter	Single Stage, Paper

Fuel Consumption

Prime power at 3000rpm	56.5 liters/h
Standby Power at 3000rpm	62.2 liters/h

Lubrication System

Lub. Oil Pan Capacity	25 liters
Max. allowable Oil Temp	110 degree C.
Oil pressure	Min. 294 kPa Max. 490 kPa

Engineering Data

Combustion Air	15.00m ³ /min
Exhaust Gas	36.50m ³ /min

Conversion Table

PS = kW × 1.3596	in. = mm × 0.0394
psi = kg/cm ² × 14.2233	
HP= PS x 0.98635	

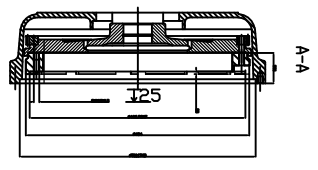
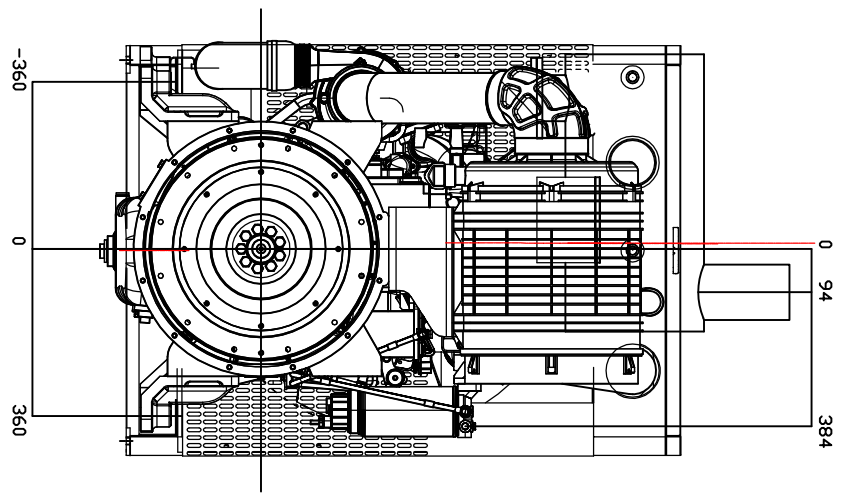
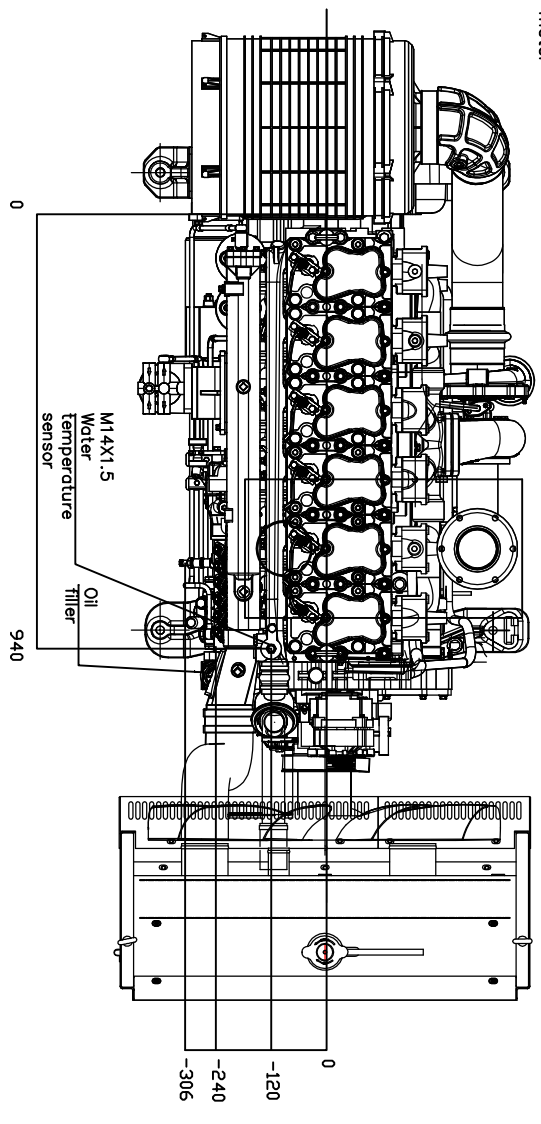
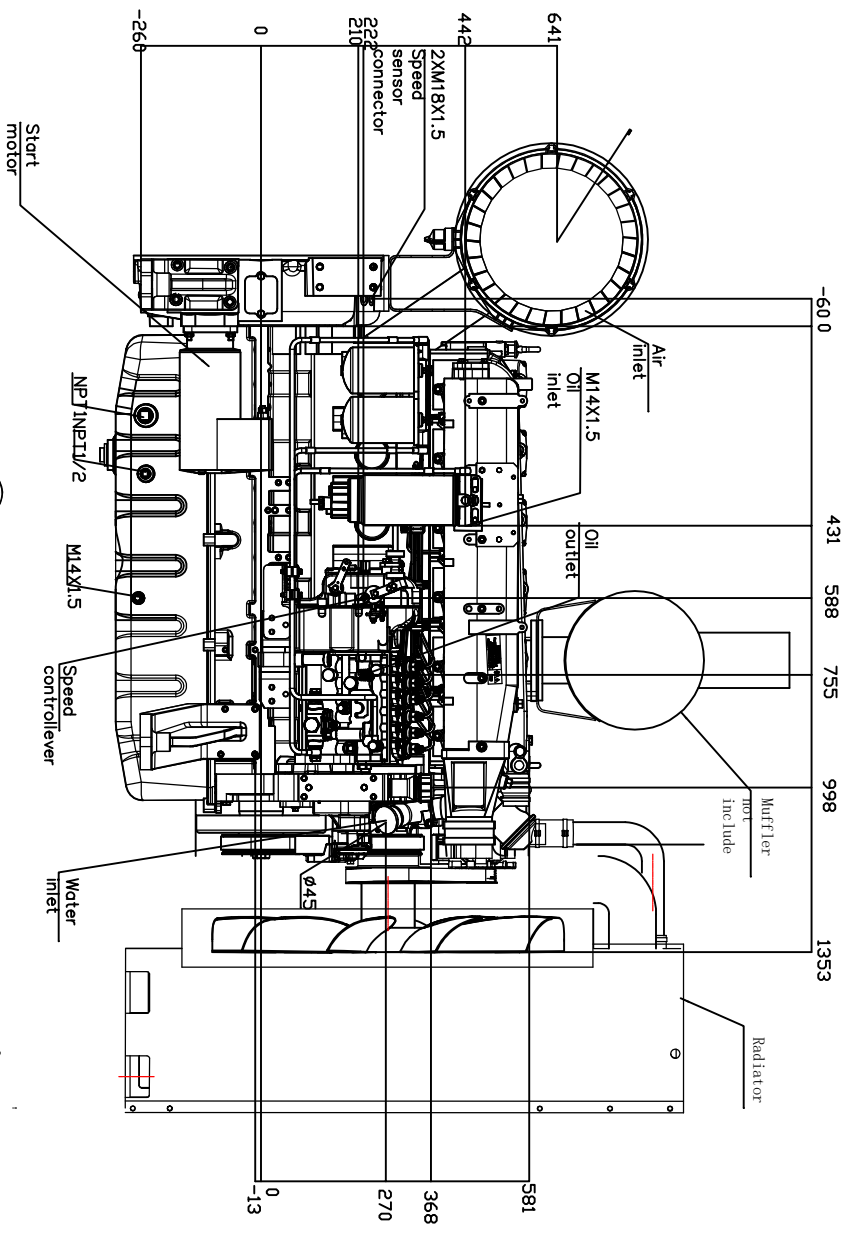

SCALE	1/5	DATE	KOODEC ENGINE ASSEMBLY	
DESIGN	-	13/10/77	CONTRACT	NO. 202072-00
CHKD	-	-	SPCL. NO.	KOP-215
APPROVAL	-	-	REVISED	-
CLIENT	APR 2004	-	REVISION	-