

DIESEL ENGINE

KDPU SERIES FOR INDUSTRIAL POWER UNIT

Model:6KDPU-117	Prime power	107.0KW(145.0HP)/1900 rpm
	Standby Power	117.0KW(159.0HP)/1900 rpm

- The engine performance is as per ISO 3046. Type of operation is based on ISO 8528.
- Prime power is available for an unlimited number of hours per year in a variable load application.
- The permissible average power output over 24 hours of operation shall not exceed 80% of the prime power rating.

Engine Specifications

In-Line, 4 stroke, water-cooled, Turbocharged	
Combustion type	Direct injection
Cylinders - Bore × stroke	6 - 105 × 125 mm
Displacement	6494 cc
Firing order	1-5-3-6-2-4
Compression ratio	16 : 1
Dry weight	Approx. 670 kg
Dimension(LxWxH)	1,380 × 740 × 1,275 mm
Rotation	Anti-clockwise
Flywheel / Housing	SAE # 11.5 / # 3

Fuel System

Injection pump	Direct Injection type
Governor	Electronic type
Feed pump	Mechanical type
Injection nozzle	Multi-hole type/ 0.255 mm
Opening pressure	25+0.5MPa
Fuel filter	Single Stage, Paper

Fuel Consumption

Prime power at 1900rpm	29.9 liters/h
Standby power at 1900rpm	32.9 liters/h

Cooling System

Cooling method	Fresh water forced type
Water pump	Centrifugal, Belt driven
Water Capacity	13.8 liters (engine only)
Max. water Temp	95 degree C.
Cooling Fan	Blade 7EA - Ø 560 mm

Lubrication System

Lub. Oil Pan Capacity	16.0 liters
Max. allowable Oil Temp	110 degree C.
Oil pressure	Min. 294 kPa Max. 490 kPa

Intake & Exhaust System

Max air restriction	Clean 2 kPa / Dirty 5 kPa
Exhaust back	Max 6 kPa

Engineering Data

Combustion Air at 1900rpm	10.9 m3/min
Exhaust Gas at 1900rpm	27.2 m3/min

Electric System

Charging generator	27.5 V × 36 A
Starting motor	12 V × 7.5 kW
Battery	12 V x 2 x 120 Ah

Conversion Table

PS = kW × 1.3596	in. = mm × 0.0394
psi = kg/cm ² × 14.2233	
HP= PS x 0.98635	

8KDP-U-117

CM. 3846

1381

154

103

221

912

599

92

153

163

2

3

4

5

6

7

8

9

0

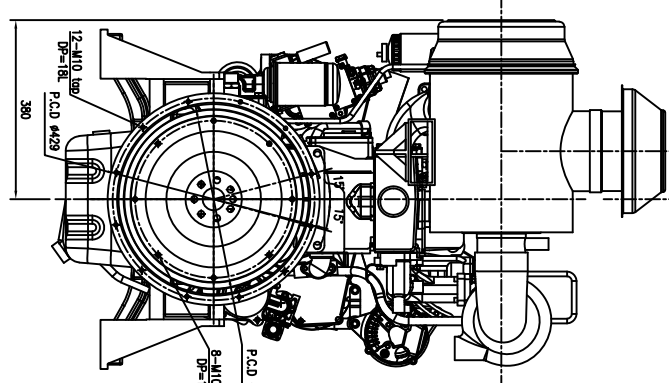
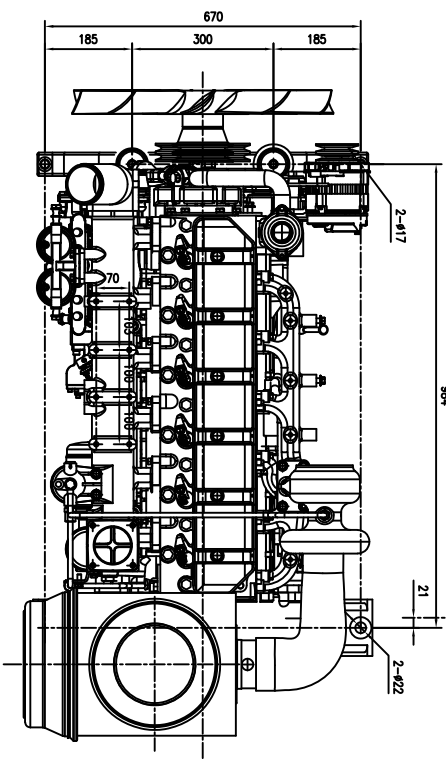
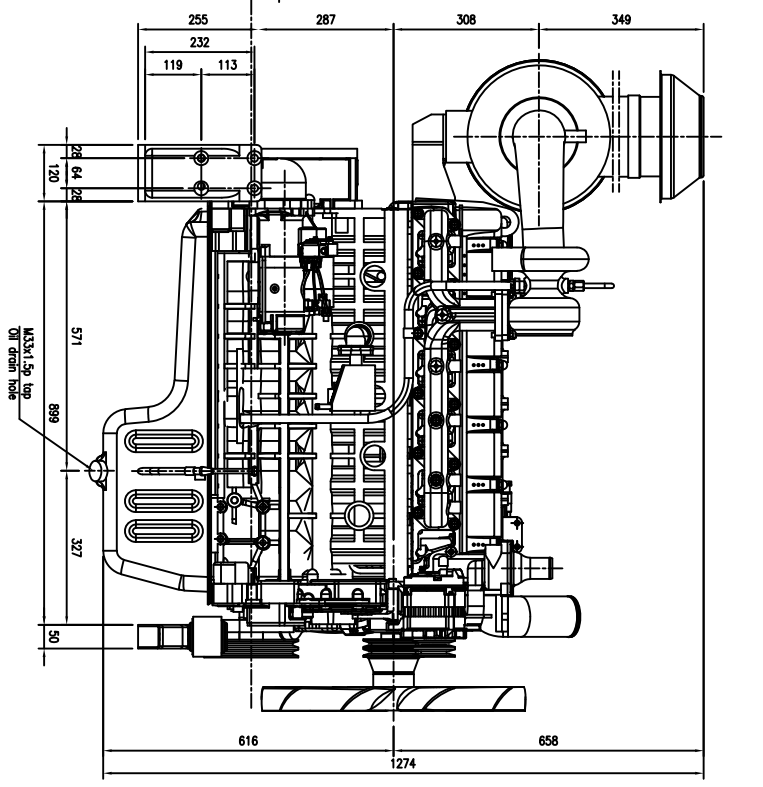
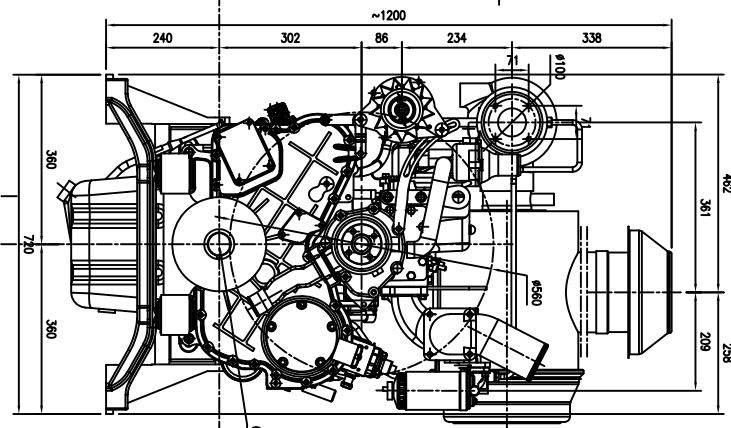
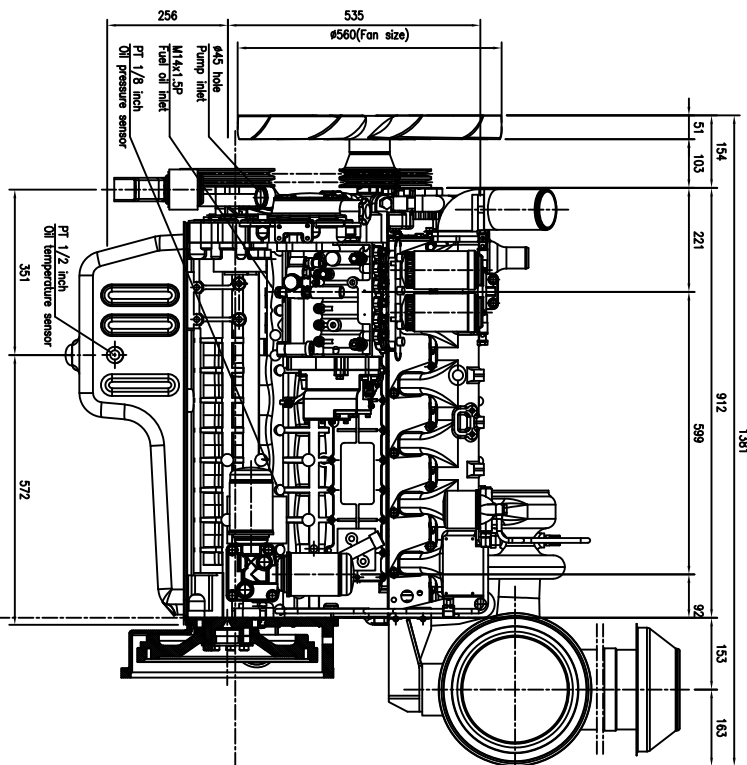

NOTE:
FLYWHEEL : SAE #11.5
FLYWHEEL HOUSING : SAE #3

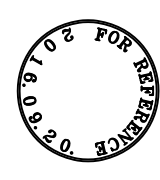

CUSTOMER		TITLE	
-		KODDEC ENGINE ASSEMBLY	
8KDP-U-117		8KDP-U-117 (117KWE1900rpm)	
SCALE	1/12	DATE	14.09.20
DESIGNED	-	CHECKED	-
DRAWN	-	APPROVED	-
REVISED	-	REVISED	-
NO.	00	NO.	00
REVISED	00	REVISED	00

